

Department of Industrial Engineering

BSIE Course Planning Guide

Fall 2024

Updated September 25, 2024

Important dates for Spring 2025 Registration

**Due date for Course Planning Assignment
to be submitted on Canvas
October 21, 2024**

**Registration Opens
November 6, 2024**

***Check for your specific time ticket in iROAR**

Table of Contents

1	VERY IMPORTANT POLICIES	3
2	IMPORTANT CHANGES.....	3
3	Advising in IE.....	4
3.1	Academic advising	4
3.2	What you can expect from your academic advisor.....	4
3.3	What your academic advisor expects from you:	4
3.4	Advising Process/pre-registration.....	4
3.5	Faculty advising.....	5
3.6	What you can expect from your faculty advisor.....	5
3.7	What your faculty advisor expects from you:	5
3.8	Interacting with your advisors	5
3.9	How to identify your advisors & set up appointments	5
3.10	Course Planning Worksheet	6
4	BSIE Curricula.....	7
4.1	The 2016-2021 IE curriculum	7
4.2	The 2018-2021 IE curriculum (with computing emphasis).....	8
4.3	The 2022 and later IE curriculum (127).....	9
4.4	The 2022 and later IE curriculum - computing emphasis.....	10
5	Material for all curricula	11
5.1	Lists of Approved Courses	11
5.2	Information for ROTC Students	14
5.3	Information regarding the Fundamentals of Engineering Exam	14
5.4	Prerequisites.....	15
6	Planned Course Offerings	16
7	Study Abroad	16
8	Co-op Schedules	17
9	Changing majors into IE	17
9.1	Changing into IE from General Engineering.....	17
9.2	Changing into IE from other majors.....	18
9.3	How to change majors	18
10	Additional Registration and Course Planning Topics	18
10.1	Credit to be earned at another school	18
10.2	Petitions	18
10.3	Enrolling in a course and its prerequisites concurrently.....	19
10.4	IE course attempt policy (2016 – 2017 catalog year and later).....	19
10.5	Graduate Coursework	19
11	Expanding Experiences Outside of the Classroom	19
11.1	Creative Inquiry (CI).....	19
11.2	IE 2680: CI Seminar	20
11.3	Departmental Honors	20
11.4	Course and curriculum requirements of other departments.....	20
12	Information for Non-IE and Transfer Students	20
13	IE Objectives and Outcomes	20

All colleges and departments establish certain academic requirements that must be met before a degree is granted. Advisors, department chairs, and deans are available to help the student understand and meet these requirements; but the student is responsible for fulfilling them. If, at the end of a student's course of study, the requirements for graduation have not been satisfied, the degree will not be granted. For this reason, it is important for students to acquaint themselves with all academic requirements throughout their college careers and to be responsible for completing all requirements within prescribed deadlines and time limits. –*Policy of Student Responsibility, Undergraduate Catalog*

1 VERY IMPORTANT POLICIES

1. Students who fail to pass an IE course with a D or better within three attempts will be dismissed from the program (see Section 10.4).
2. For all IE courses, a D is a passing grade. However, some of the prerequisite courses have to be completed with a C or better:
 - a. In order to register for IE 3600 a student must have a C in MATH 2060
 - b. In order to register for IE 3800 a student must have a C in MATH 3110
 - c. In order to register for IE 3810 a student must have a C in MATH 3110
 - d. If you are taking the Computing Emphasis, you must get a C or better in the CPSC courses.

2 IMPORTANT CHANGES

1. Effective fall 2022, CE 2010 is no longer a prerequisite for IE 2100. It is still a required course for student in the 2021 and earlier catalog years. Students need only have a D or better to satisfy CE 2010.
2. Effective fall 2022, IE 4650 is no longer a prerequisite for IE 4670.
3. Effective fall 2022, IE 4650 is no longer a required course. Instead, IE 4650 has been replaced with the ***IE Integrating Elective***, which requires one of IE 4460, 4560, 4640, 4650 or 4890.
 - The Integrating elective is in addition to the IE Technical Requirements!
 - Please review prerequisites for these classes carefully!
4. Effective fall 2022, IE 3140 is renumbered as IE 2140 (and general engineering students can take it)
5. Effective fall 2023, IE 2140 is a new prerequisite for IE 3860

3 Advising in IE

The advising structure in the Department of Industrial Engineering is composed of two types of advising with different goals and processes.

3.1 Academic advising

Academic advisors are professional advisors within the Department of Industrial Engineering and are assigned by your last name:

A-G: Jess LeCroy (jpruszk@clemson.edu)

H-Z: Susan Long (sllong@clemson.edu)

3.2 What you can expect from your academic advisor:

- You can contact your academic advisor for questions related to (but not limited to): your course schedule, registration, course plans, curriculum matters, and signing/processing student forms, success strategies in college.
- Informs you of administrative, academic, and personal services and resources.
- Offers regular office hours or appointment times in order to meet with you.
- Approves all student forms (e.g., coursework elsewhere, forgiveness, GS6 forms)
- Protects your privacy of student information as set forth in The Family Educational Rights and Privacy Act (FERPA)
- Refers students to appropriate resources (both academic and personal) for issues that may require intervention by other professionals.

3.3 What your academic advisor expects from you:

- Meeting requirement: your first two semesters in IE, you MUST schedule in-person meetings with your academic advisor. Following the first two semesters, you can either meet in person or have your course plan reviewed through CANVAS only.
- Make an appointment with your assigned advisor BEFORE registration begins using CU Navigate.
- SHOW UP PREPARED: Have your course plan completed and forms filled out.
- Seek assistance and guidance when curriculum planning and/or wishing to change majors.
- Follow through on next steps identified in your advising session.
- Be aware of your academic standing at all times.
- Be aware of important dates and deadlines on the academic calendar.
- Accept final responsibility for all decisions. That means that you are fully responsible for your course scheduling, registration, and making degree progress.

3.4 Advising Process/Pre-registration

How do I get my PIN to register?

1. Complete a course planning worksheet from now until your graduation following all curriculum requirements, prerequisites, and your remaining course requirements.
2. Submit plan in the CANVAS assignment in the "IE Department" workgroup for the appropriate registration advising 'assignment'.
3. If you submitted a viable course plan following the guidelines above, your grade for that 'assignment' will be your 6-digit PIN to register. If your plan contains errors, you will be given feedback and will be required to resubmit a correct plan. You will not receive your PIN until a viable plan is submitted.

There are two options for pre-registration advising: one-on-one appointments or workshop advising. Note that in your first two semesters in IE, you must attend one of these advising options.

1. **Appointments:** Select "preregistration advising" as your appointment type in CU Navigate and you will find the times available to meet with your academic advisor about preregistration

2. **Workshops:** Throughout preregistration season, the department holds workshops on how to successfully complete the course planning worksheet and answer question you may have about curriculum requirements. The goal at the end of these workshops is to have to you submit an accurate plan in CANVAS.

3.5 Faculty advising

Your assigned faculty member on your success team helps you with all career advising. Your faculty advisor is identified in the ‘Your Success Team’ section of CU Navigate.

3.6 What you can expect from your faculty advisor:

- You can discuss anything related (but not limited to) career options, graduate school, co-ops, internships, professional development, minors in other programs, and course information
- Direct students to resources for strategies for success in college, the job search process, resume review
- Assist students in exploring career and professional opportunities.
- Offers regular office hours or appointment times in order to meet with you.
- Help select or suggest courses based on career and educational goals.
- Protect your privacy of student information as set forth in The Family Educational Rights and Privacy Act (FERPA).
- Refer students to appropriate resources (both academic and personal) for issues that may require intervention by other professionals.

3.7 What your faculty advisor expects from you:

- Meeting requirement: You are expected to meet with your faculty advisor at least once an academic year.
- SHOW UP PREPARED: Know what you want to talk about; bring appropriate materials based on faculty advisor request.
- Engage in active dialogue with advisor.
- Follow through on next steps outlined in career advising meeting.
- Take ownership for your own education experience.

3.8 Interacting with your advisors

3.9 How to identify your advisors & set up appointments

We use CU Navigate (available at <https://clemsun.campus.eab.com/> and as the “Guide” app from the Google Play or Apple app stores) to schedule meetings and communicate with advisors.

Identifying your advisors

1. On your CU Navigate home page you will see “Your Success Team” listed in the bottom right corner.
2. Your academic and faculty advisors are both identified.

To make an appointment with either your academic or your faculty advisors:

1. “Schedule an Appointment”
2. Select your scheduling options
3. Select “Industrial Engineering” for your location
4. Choose your day and time from the times that are identified as available.
5. Include any information that will tell your advisor what the appointment is regarding and help them prepare for your appointment.

If you need to cancel an existing appointment: click the appointment you need to cancel in your upcoming appointments list and click “Cancel my attendance”. Provide a reason and any additional comments.

Additional information and guides for using CU Navigate:

<https://www.clemson.edu/academics/advising/cunavigate/guide/resource-page.html>

3.10 Course Planning Worksheet

Your academic advisor or faculty advisor will review the course plan you submit in CANVAS and distribute your PIN to you through the CANVAS grade book.

The course planning worksheet is available from the IE website (ie.clemson.edu). In order to properly fill out the course planning worksheet, you will need to gather information from DegreeWorks and this document. Degree Work will help you identify your current standing, completed and remaining requirements, GPA, etc.

Your catalog year is available to you in DegreeWorks.

The screenshot displays the DegreeWorks interface. At the top, there are input fields for Student ID, Name, and Degree (Bachelor of Science). Below these are search filters for Level (Undergraduate), Classification (Senior), Major (Industrial Engineering), Minor, and Program (BS Industrial Engineering). The interface is divided into 'Academic' and 'What-If' tabs. Under 'Academic', there is a 'Format' dropdown set to 'Student View', 'Degree progress' showing an 'Overall GPA' of 3.24, and checkboxes for 'In-progress classes' and 'Preregistered classes' with a 'Process' button. The 'Audit date' is 2/5/2021 8:10 AM. The main section shows 'Bachelor of Science Degree' with an 'INCOMPLETE' status. Below this, it lists 'Credits required: 125' and 'Credits applied (includes In-progress):'. A red box highlights the 'Catalog year: 2018-2019' field, with three red arrows pointing to it from above.

4 BSIE Curricula

IE courses are offered each fall and spring semester. IE classes can be taken in any semester as long as prerequisite and other requirements are satisfied. If you are on a catalog year prior to 2016, please contact your academic advisor for your curriculum and curriculum related questions. **Your catalog year is identified at the top of the degree works page.**

4.1 The 2016-2021 IE curriculum

Year 1			
17	First Semester	17	Second Semester
4	CH 1010 General Chemistry	3	ENGR 1410 Programming
3	ENGL 1030 Comp. & Rhetoric	4	MATH 1080 Calc of One Var II
3	ENGR 1020 Engr Discip. & Skills	3	PHYS 1220 Physics I
4	MATH 1060 Calc. of One Var I	3	Arts and Human./Social Sciences ⁵
3	Arts and Human./Social Sciences ⁵	4	Lab Science Requirement ⁵
Year 2			
16	First Semester	17	Second Semester
3	CE 2010 Statics ⁶	3	IE 2100 Design and Ana. Of Work Sys.
4	MATH 2060 Calc. of Several Var. ²	4	IE 3010 Systems Design I
3	MATH 3110 Linear Algebra ²	1	IE 2140 Seminar in IE
3	PHYS 2210 Physics with Calc. II	3	IE 3600 Ind. App. Of Prob./Stat. I ⁴
1	PHYS 1240 Physics Lab. II ³	3	IE 3800 Deterministic Oper. Res. ⁴
2	ENGR 2080 (or 2090 or 2100)	3	MSE 2100 Intro to Mater. Science
Year 3			
15	First Semester	16	Second Semester
3	IE 3610 Ind. App. Of Prob./Stat. II	3	IE 3860 Production Plan. And Cont.
3	IE 3810 Probabilistic Oper. Res. ⁴	3	IE 4610 Quality Engineering
3	IE 3840 Engr. Economic Ana.	3	<i>IE Integrating Elective</i> ⁸
3	IE 4400 Dec. Support Systems in IE	4	IE 4820 Systems Modeling
3	Arts and Human./Social Sciences ⁵	3	Oral Communication ⁵
Year 4			
15	First Semester	13	Second Semester
3	IE 4880 Human Factors Engr.	4	IE 4670 Systems Design II
6	<i>IE Technical Requirement</i> ^{5,7,9}	3	<i>IE Technical Requirement</i> ^{5,7}
3	ECE 2070/2080 or 2020/2110	3	Management Requirement ⁵
3	Ethics and Prof. Practice ⁵	3	Arts and Human./Social Sciences ⁵

1 Refer to the General Engineering first year curriculum.

2 This course must be passed with a C or better as a prereq for other courses.

3 PHYS 2230 may be substituted.

4 This course has prereq with C or better requirements.

5 Select from the list in Degree Works or Section 5.1

6 ME 2010 completed with a C or better can be used to satisfy this requirement.

7 At most 3 credits of IE technical elective can be substituted with 3 credits from the Broadening list.

8 Starting in Fall 2022, any IE Integrating Elective may be taken. Select from IE 4460, IE 4560, IE 4640, IE 4650, or IE 4890.

9 The New (Fall 23) course CPSC 1050 may be used as well but requires a course substitution.

4.2 The 2018-2021 IE curriculum (with computing emphasis)

Year 1			
16	First Semester	17	Second Semester
4	CH 1010 General Chemistry	3	ENGR 1410 Programming
3	ENGL 1030 Comp. & Rhetoric	4	MATH 1080 Calc of One Var II
3	ENGR 1020 Engr Discip. & Skills	3	PHYS 1220 Physics I
4	MATH 1060 Calc. of One Var I	3	Arts and Human./Social Sciences ⁵
3	Arts and Human./Social Sciences ⁵	4	Lab Science Requirement ⁵
Year 2			
16	First Semester	17	Second Semester
3	CE 2010 Statics ⁶	4	CPSC 1020 Computer Science II ⁷
4	CPSC 1010 Computer Science I ⁷	3	IE 2100 Design and Ana. Of Work Sys.
4	MATH 2060 Calc. of Several Var. ²	4	IE 3010 Systems Design I
3	MATH 3110 Linear Algebra ²	3	IE 3600 Ind. App. Of Prob./Stat. I ⁴
2	ENGR 2080 (or 2090 or 2100)	3	IE 3800 Deterministic Oper. Res. ⁴
Year 3			
17	First Semester	16	Second Semester
3	IE 3610 Ind. App. Of Prob./Stat. II	3	IE 3860 Production Plan. And Cont.
3	IE 3810 Probabilistic Oper. Res. ⁴	3	IE 4610 Quality Engineering
3	IE 3840 Engr. Economic Ana.	3	<i>IE Integrating Elective</i> ⁸
3	IE 4400 Dec. Support Systems in IE	4	IE 4820 Systems Modeling
3	PHYS 2210 Physics with Calc. II	3	Oral Communication ⁵
1	PHYS 1240 Physics Lab. II ³		(IE 2140 will be a preq for IE 3860 effective
1	IE 2140 Seminar in IE		Fall 2023 – take it ASAP!)
Year 4			
15	First Semester	13	Second Semester
4	CPSC 2120 Algorithms & Data Struct.	4	IE 4670 Systems Design II
3	ECE 2070/2080 or 2020/2110	3	MSE 2100 Intro to Mater. Science
3	IE 4880 Human Factors Engr.	3	Management Requirement ⁵
3	Social Science Requirement ⁵	3	Arts and Human./Social Sciences ⁵
3	Ethics and Prof. Practice. ⁵		

1 Refer to the General Engineering first year curriculum.

2 This course must be passed with a C or better as a prereq for other courses.

3 PHYS 2230 may be substituted.

4 This course has prereq with C or better requirements.

5 Select from the list in Degree Works or Section 5.1

6 ME 2010 completed with a C or better can be used to satisfy this requirement.

7 CPSC 1060 or CPSC 1110 may be used instead of CPSC 1010. CPSC 1070 may be used instead of CPSC 1020. CPSC 1010 or CPSC 1060 is strongly recommended over CPSC 1110.

8 Starting in Fall 2022, any IE Integrating Elective may be taken. Select from IE 4460, IE 4560, IE 4640, IE 4650, or IE 4890.

4.3 The 2022-2023 and 2023-2024 IE curriculum

Year 1		31	
17	First Semester	14	Second Semester
4	CH 1010 General Chemistry ¹	3	ENGR 1410 ¹
3	ENGL 1030 Comp. & Rhetoric ¹	4	MATH 1080 Calc of One Var II ¹
3	ENGR 1020 Engr Discip. & Skills ¹	3	PHYS 1220 Physics I ¹
4	MATH 1060 Calc. of One Var I ¹	1	PHYS 1240 Physics Lab. I ²
3	Arts and Human./Social Sciences ^{4,7}	3	Arts and Human./Social Sciences ⁴
Year 2		33	
16/17	First Semester	17/16	Second Semester
3/4	IE 2100 Design and Ana. Of Work Sys. OR IE 3010 Systems Design I	4/3	IE 3010 Systems Design I OR IE 2100 Design and Ana. Of Work Sys.
4	MATH 2060 Calc. of Several Var. ¹	3	IE 3600 Ind. App. Of Prob./Stat. I ³
3	MATH 3110 Linear Algebra ¹	3	IE 3800 Deterministic Oper. Res. ³
3	PHYS 2210 Physics with Calc. II	4	CPSC 1010 or 1060 or 1110 ^{5,8}
1	IE 2140 Seminar in IE	3	Oral Communication ⁴
2	ENGR 2080 / 2090/ 2100		
Year 3		31	
15	First Semester	16	Second Semester
3	IE 3610 Ind. App. Of Prob./Stat. II	3	IE 3860 Production Plan. And Cont.
3	IE 3810 Probabilistic Oper. Res. ³	3	IE 4610 Quality Engineering
3	IE 3840 Engr. Economic Ana.	3	Engineering Science Requirement ⁴
3	IE 4400 Dec. Support Systems in IE	4	IE 4820 Systems Modeling
3	Engineering Science Requirement ⁴	3	Arts and Human./Social Sciences ⁴
Year 4		32	
16	First Semester	16	Second Semester
3	IE 4880 Human Factors Engr.	4	IE 4670 Systems Design II
3	IE Technical Requirement ⁴	3	IE Integrated Elective ⁴
3	Engineering Science Requirement ⁴	3	Broadening Elective ^{4,6,7}
3	Broadening Elective ^{4,6,7}	3	Arts and Human./Social Sciences ⁴
4	Lab Science Requirement ⁴	3	IE Technical Requirement ⁴

1 This course must be passed with a C or better as a prereq for other courses.

2 PHYS 2230 may be substituted.

3 This course has prereq with C or better requirements.

4 Select from list in Degree Works or Section 5.1

- Must satisfy the REACH Act graduation requirement as listed in the Academic Regulations section of the catalog. Requirement may not be applicable to all students. See Academic Regulations for more information. Can use REACH Act courses in the Broadening Elective
- Crossings: must satisfy the crossings requirement. Can use up to 3 credits non-IE courses as Broadening Elective.

5 If CPSC 1110 is used, an additional 1 unit free elective must be taken

6 Students must select courses to satisfy the Global Challenges General Education Requirement. ENGR 1020 and IE 4880 (taken at Clemson) will satisfy this requirement. Global Challenges courses may be in the list of courses for Broadening Electives.

7 Students must satisfy the REACH Act requirements. Some coursework satisfying the REACH Act

Requirements may also be on the Social Sciences General Education list or the Broadening Electives List.

8 The New (Fall 23) course CPSC 1050 may be used as well but requires a course substitution.

4.4 The 2022-2023 and 2023-2024 IE curriculum (with computing emphasis)

Year 1		31
17	First Semester	14
4	CH 1010 General Chemistry ¹	3
3	ENGL 1030 Comp. & Rhetoric ¹	4
3	ENGR 1020 Engr Discip. & Skills ¹	3
4	MATH 1060 Calc. of One Var I ¹	1
3	Arts and Human./Social Sciences ^{4, 7}	3
Second Semester		
	ENGR 1410 ¹	
	MATH 1080 Calc of One Var II ¹	
	PHYS 1220 Physics I ¹	
	PHYS 1240 Physics Lab. I ²	
	Arts and Human./Social Sciences ⁴	
Year 2		32
17/18	First Semester	14/15
3/4	IE 2100 Design and Ana. Of Work Sys.	4/3
4	OR IE 3010 Systems Design I	
4	MATH 2060 Calc. of Several Var. ¹	3
3	MATH 3110 Linear Algebra ¹	3
3	PHYS 2210 Physics with Calc. II	1
4	Computing Emphasis Course 1 ^{1,5}	4
Second Semester		
	IE 3010 Systems Design I OR	
	IE 2100 Design and Ana. Of Work Sys.	
	IE 3600 Ind. App. Of Prob./Stat. I ³	
	IE 3800 Deterministic Oper. Res. ³	
	IE 2140 Seminar in IE	
	Computing Emphasis Course 2 ^{1,5}	
Year 3		32
16	First Semester	16
3	IE 3610 Ind. App. Of Prob./Stat. II	3
3	IE 3810 Probabilistic Oper. Res. ³	3
3	IE 4400 Dec. Support Systems in IE	3
3	Engineering Science Requirement ⁴	4
4	CPSC 2120 Algorithms & Data Struct. ¹	3
Second Semester		
	IE 3860 Production Plan. And Cont.	
	IE 4610 Quality Engineering	
	Engineering Science Requirement ⁴	
	IE 4820 Systems Modeling	
	Arts and Human./Social Sciences ⁴	
Year 4		32
16	First Semester	16
3	IE 4880 Human Factors Engr.	4
3	IE 3840 Engr. Economic Ana.	3
3	Engineering Science Requirement ⁴	3
3	Oral Communication ⁴	3
4	Lab Science Requirement ⁴	3
Second Semester		
	IE 4670 Systems Design II	
	IE Integrated Elective ⁴	
	Computing Emphasis Course ⁵	
	Arts and Human./Social Sciences ⁴	
	Broadening Elective ^{4, 6, 7}	

1 This course must be passed with a C or better as a prereq for other courses.

2 PHYS 2230 may be substituted.

3 This course has prereq with C or better requirements.

4 Select from the list in Degree Works or Section 5.1

5 Computing Emphasis requires

CPSC 1010 and 1020 and 2120 and (one of CPSC 2150, CPSC 2070, CPSC 2310, CPSC 3120, CPSC 3500, CPSC 4030, CPSC 4040, CPSC 4050, CPSC 4120, CPSC 4180, CPSC 4300, CPSC 4420, CPSC 4430, CPSC 4550) OR

CPSC 1060 and 1070 and 2120 and (one of CPSC 2150, CPSC 2070, CPSC 2310, CPSC 3120, CPSC 3500, CPSC 4030, CPSC 4040, CPSC 4050, CPSC 4120, CPSC 4180, CPSC 4300, CPSC 4420, CPSC 4430, CPSC 4550)

CPSC 1110 can be used instead of CPSC 1010 with the addition of 1unit free elective

6 Students must select courses to satisfy the Global Challenges General Education Requirement. ENGR 1020 and IE 4880 (taken at Clemson) will satisfy this requirement. Global Challenges courses may be in the list of courses for Broadening Electives.

7 Students must satisfy the REACH Act requirements. Some coursework satisfying the REACH Act.

Requirements may also be on the Social Sciences General Education list or the Broadening Electives List.

4.5 The 2024-2025 IE curriculum

Year 1		33
17	First Semester	16
4	CH 1010 General Chemistry ¹	3
3	ENGL 1030 Comp. & Rhetoric ¹	4
3	ENGR 1020 Engr Discip. & Skills ¹	3
4	MATH 1060 Calc. of One Var I ¹	6
3	Arts and Human./Social Sciences ^{3,6}	
Year 2		33
16/17	First Semester	17/16
3/4	IE 2100 Design and Ana. Of Work Sys. OR IE 3010 Systems Design I	4/3
4	MATH 2060 Calc. of Several Var. ¹	3
3	MATH 3110 Linear Algebra ¹	3
3	PHYS 2210 Physics with Calc. II	4
1	IE 2140 Seminar in IE	3
2	ENGR 2080 / 2090/ 2100	
Year 3		31
15	First Semester	16
3	IE 3610 Ind. App. Of Prob./Stat. II	3
3	IE 3810 Probabilistic Oper. Res. ²	3
3	IE 3840 Engr. Economic Ana.	3
3	IE 4400 Dec. Support Systems in IE	4
3	Engineering Science Requirement ³	3
Year 4		29
16	First Semester	13
3	IE 4880 Human Factors Engr.	4
3	IE Technical Requirement ³	3
3	Engineering Science Requirement ³	3
3	Broadening Elective ^{3,5,6}	3
4	Lab Science Requirement ³	
Second Semester		
	ENGR 1410 ¹	
	MATH 1080 Calc of One Var II ¹	
	PHYS 1220 Physics I ¹	
	Arts and Human./Social Sciences ³	
	IE 3010 Systems Design I OR	
	IE 2100 Design and Ana. Of Work Sys.	
	IE 3600 Ind. App. Of Prob./Stat. I ²	
	IE 3800 Deterministic Oper. Res. ²	
	CPSC 1010 or 1050 or 1060 or 1110 ⁴	
	Oral Communication ³	
	IE 3860 Production Plan. And Cont.	
	IE 4610 Quality Engineering	
	Engineering Science Requirement ³	
	IE 4820 Systems Modeling	
	Arts and Human./Social Sciences ³	
	IE 4670 Systems Design II	
	IE Integrated Elective ³	
	Broadening Elective ^{3,5,6}	
	IE Technical Requirement ⁴	

1 This course must be passed with a C or better as a prereq for other courses.

2 This course has prereq with C or better requirements.

3 Select from list in Degree Works or Section 5.1

- a. Must satisfy the REACH Act graduation requirement as listed in the Academic Regulations section of the catalog. Requirement may not be applicable to all students. See Academic Regulations for more information. Can use REACH Act courses in the Broadening Elective
- b. Crossings: must satisfy the crossings requirement. Can use up to 3 credits non-IE courses as Broadening Elective.

4 If CPSC 1110 is used, an additional 1 unit free elective must be taken

5 Students must select courses to satisfy the Global Challenges General Education Requirement. ENGR 1020 and IE 4880 (taken at Clemson) will satisfy this requirement. Global Challenges courses may be in the list of courses for Broadening Electives.

6 Students must satisfy the REACH Act requirements. Some coursework satisfying the REACH Act.

Requirements may also be on the Social Sciences General Education list or the Broadening Electives List.

4.6 The 2024-2025 IE curriculum (with computing emphasis)

Year 1		33
17	First Semester	16
4	CH 1010 General Chemistry ¹	3
3	ENGL 1030 Comp. & Rhetoric ¹	4
3	ENGR 1020 Engr Discip. & Skills ¹	3
4	MATH 1060 Calc. of One Var I ¹	6
3	Arts and Human./Social Sciences ^{3,6}	
Year 2		32
17/18	First Semester	14/15
3/4	IE 2100 Design and Ana. Of Work Sys. OR IE 3010 Systems Design I	4/3
4	MATH 2060 Calc. of Several Var. ¹	3
3	MATH 3110 Linear Algebra ¹	3
3	PHYS 2210 Physics with Calc. II	1
4	Computing Emphasis Course 1 ^{1,4}	4
Year 3		32
16	First Semester	16
3	IE 3610 Ind. App. Of Prob./Stat. II	3
3	IE 3810 Probabilistic Oper. Res. ²	3
3	IE 4400 Dec. Support Systems in IE	3
3	Engineering Science Requirement ³	4
4	CPSC 2120 Algorithms & Data Struct. ¹	3
Year 4		30
16	First Semester	14
3	IE 4880 Human Factors Engr.	4
3	IE 3840 Engr. Economic Ana.	3
3	Engineering Science Requirement ³	4
3	Oral Communication ³	3
4	Lab Science Requirement ³	
Second Semester		
	ENGR 1410 ¹	
	MATH 1080 Calc of One Var II ¹	
	PHYS 1220 Physics I ¹	
	Arts and Human./Social Sciences ³	
	IE 3010 Systems Design I OR IE 2100 Design and Ana. Of Work Sys.	
	IE 3600 Ind. App. Of Prob./Stat. I ²	
	IE 3800 Deterministic Oper. Res. ²	
	IE 2140 Seminar in IE	
	Computing Emphasis Course 2 ^{1,4}	
	IE 3860 Production Plan. And Cont.	
	IE 4610 Quality Engineering	
	Engineering Science Requirement ³	
	IE 4820 Systems Modeling	
	Arts and Human./Social Sciences ³	
	Second Semester	
	IE 4670 Systems Design II	
	IE Integrated Elective ³	
	Computing Emphasis Course ⁴	
	Broadening Elective ^{3,5,6}	

1 This course must be passed with a C or better as a prereq for other courses.

2 This course has prereq with C or better requirements.

3 Select from the list in Degree Works or Section 5.1

4 Computing Emphasis requires

CPSC 1010 and 1020 and 2120 and (one of CPSC 2150, CPSC 2070, CPSC 2310, CPSC 3120, CPSC 3500, CPSC 4030, CPSC 4040, CPSC 4050, CPSC 4120, CPSC 4180, CPSC 4300, CPSC 4420, CPSC 4430, CPSC 4550) OR

CPSC 1060 and 1070 and 2120 and (one of CPSC 2150, CPSC 2070, CPSC 2310, CPSC 3120, CPSC 3500, CPSC 4030, CPSC 4040, CPSC 4050, CPSC 4120, CPSC 4180, CPSC 4300, CPSC 4420, CPSC 4430, CPSC 4550)

CPSC 1110 can be used instead of CPSC 1010 with the addition of 1unit free elective

5 Students must select courses to satisfy the Global Challenges General Education Requirement. ENGR 1020 and IE 4880 (taken at Clemson) will satisfy this requirement. Global Challenges courses may be in the list of courses for Broadening Electives.

6 Students must satisfy the REACH Act requirements. Some coursework satisfying the REACH Act. Requirements may also be on the Social Sciences General Education list or the Broadening Electives List.

5 Material for all curricula

5.1 Lists of Approved Courses

DegreeWorks provides a list of the current set of courses associated with your degree. Please consult your course advisor if there appears to be an error.

2021 and earlier Catalog Years only

Ethics & Professional Practice Req: 3 units

PHIL 1030
PHIL 3440
PHIL 3450
PHIL 3460
LAW 3220

Management Requirement: 3 units

ACCT 2010 MGT 3070
AS 3090 MGT 4110
E L E 4000 MKT 4210
MGT 2010 ML 3010

Lab Science Requirement – All Catalog Years

BIOL 1030 and 1050
BIOL 1040 and 1060
BIOL 1100
BIOL 1200 and 1220

BIOL 1200 and 1230
CH 1020
GEOL 1010/1030
GEOL 1120/1140 (by substitution for 2021 and earlier)

IE Technical Requirement – All Catalog Years

IE 4000 (6 units maximum)	IE 4560	IE 4700
IE 4040	IE 4570	IE 4810
IE 4300	IE 4580	IE 4850
IE 4460	IE 4600	IE 4860
IE 4500	IE 4620	IE 4870
IE 4510	IE 4630	IE 4890
IE 4520	IE 4640	IE 4910
IE 4530	IE 4650	

IE Integrating Elective – All Catalog Years, No double dipping with IE Technical Requirement!

IE 4460	IE 4650
IE 4560	IE 4890
IE 4640	

Engineering Science Requirement – 2022 and later Catalog Years

9 credits total, 3 different areas. Please consider prerequisites!

Topical area	At most one of these courses	
Statics	ME 2050	CE 2010
Dynamics	ME 2060	CE 2080 2 units
Electrical Engineering	ECE 2070 and 2080 4 credits	
Materials	MSE 2100	CE 3510 4 credits
Thermal and Fluids	ME 2030 2 credits	CE 3410 MSE 3260

Broadening Electives

- The number of units that can be satisfied by Broadening electives depends on your catalog year.
- If a course is not listed and you think it should be, talk to your advisor.
- The intention of the department is that these lists are as similar as possible, subject to other constraints in the curricula. Please be patient as we improve these lists!

2017 and later Catalog years - please note that this list may be edited!

All IE Technical and Integrating Requirements plus the following:

Course	Title
AGM 2050	Principles of Fabrication
AMFG 3800	Introduction to Manufacturing Systems and Processes
AMFG 4200	Collaboration and Teamwork in Manufacturing Systems (sub – not in DW)
ARCH 4240	Product Design
AUE (ME) 4620	Digital Automotive Manufacturing
BIOE 4610	International Study in Bioengineering
BT 2200	Biosystems Technology 1
CE 2060	Structural Mechanics
CE 2550	Geomatics
CE 3110	Transportation Engineering Planning and Design (sub – not in DW)
CE 3310	Construction Engineering and Management
CE 4350	Infrastructure Project Planning
CE (BE) 4400	Sustainable Energy Engineering
CE (MSE) 4530	Non-Destructive Evaluation
CE (GEOL) 4820	Groundwater and Contaminant Transport
CH 2010 or CH 2230	Survey of Organic Chemistry / Organic Chemistry
CPSC 1010 /1060 /1110	1st semester CS. CPSC 1010 or 1060 is recommended over 1110
CPSC 1050	New course (Fall 23) Python. Must submit substitution
CPSC 2920	Computing, Ethics and Global Society
CPSC 4550	Computational Science (cannot also be used in Computing Emphasis)
CRP 4010	Introduction to City and Regional Planning
CRP 4300	The Nature of Geographic Information Systems (GIS)
CTE 1150	Contemporary Technological Problems
ECE 1010	Robots in Business and Society
ECE 4420	Knowledge Engineering
EES 4140	Radioecology
EES 4860	Environmental Sustainability
ENGL 3140	Technical Writing [or ML 4010 and 4020 by sub into ENGL 3140]
ENGR 2200	Evaluating Innovations: Fixtures, Fads and Flops
ENGR 2210	Technology, Culture and Design
ENR 3120	Environmental Risks and Society
ENSP/GEOL 1250	Sustainable Resource Use
GEOL 2700	Experiences in Sustainable Development: Water
HLTH 4750	Principles of Health Care Operations Management and Research
HON 2070	Reasoning, Critical Thinking, and Problem Solving
MATH 2080	Differential Equations
MATH 3190	Intro to Proof
MATH 4190	Discrete Mathematical Structures I
MATH 4310	Theory of Interest
MATH 4350	Complex Variables
ME (AUE) 4620	Digital Automotive Manufacturing
ME 3100	Thermodynamics and Heat Transfer (sub – not in DW)
ME 4560	Additive Manufacturing

ME 4720	Manufacturing Optimization <i>Note: Credit will be given for only one of IE 4460 or ME 4720 (by substitution only)</i>
MSE 3100	Introduction to Metals and Ceramics.
MSE 3190	Materials Processing
MSE 4160	Electrical Properties of Materials
MSE 4530	Non-Destructive Evaluation
MSE 4570	Color Science
MSE 4580	Surface Phenomena in Materials Science and Engineering
PCID 3140	Technical Communication and Information Design
PSYC 3240	Physiological Psychology
PSYC 3350 (was 4350)	Human Factors Psychology
PSYC 3640	Industrial Psychology (sub – not in DW)
PSYC 3680	Organizational Psychology
PSYC 3690	Leadership in Organizational Settings
PSYC 3770	The Psychology of Group and Team Dynamics
PSYC 4220	Sensation and Perception
PSYC 4260	Advanced Physiological Psychology
PSYC 4560	Applied Psychophysiology
PSYC 4770	Teamwork Dynamics: Teams in the 21st Century
STAT 4020	Introduction to Statistical Computing
SUST 2010	Sustainability Leadership

2017-2021 only

AUE 4030	Automotive Project Tools and Prototyping (sub – not in DW)
CE 3410	Introduction to Fluid Mechanics
ELE 4070	Technology Entrepreneurship
EM 2020	Engineering Mechanics: Dynamics
ME 4550	Design for Manufacturing
MGT 4970	Deloitte Consulting CI only – by substitution only

2022 and later Catalog years but not 2017-2021 – please note that this list may be edited!

Course	Title
MATH 4110	Introduction to Combinatorics
MATH 4120	Algebra I
MATH 4340	Advanced Engineering Mathematics
MATH 4530 or 4630	Advanced Calculus I / Real Analysis I
ME 3030	Thermodynamics
ME 2070	Design of Mechanical Systems
<i>REACH Act:</i>	<i>at most 1 if not used for Soc Science Gen Ed</i> HIST 1010, POSC 1010, POSC 1030
<i>Former Ethics & Professional Practice Requirement Courses</i>	PHIL 1030, PHIL 3440, PHIL 3450, PHIL 3460, LAW 3220
<i>Former Management Requirement Courses</i>	<i>at most 1</i> ACCT 2010 MGT 3070 AS 3090 MGT 4110 E L E 4000 MKT 4210 MGT 2010 ML 3010

5.2 Information for ROTC Students

ROTC students are required to satisfy the curriculum in which they are enrolled. Several course equivalencies / substitutions exist, however:

- The ROTC Oral Communication cluster is integrated into the requirements of the 1415 and later BSIE curricula.
- ML 3010 or AS 3090 are options for the *Management / Broadening Requirement* (depending on your catalog year).
- ML 4010 and 4020 can be substituted as ENGL 3140, which can then be utilized as a *Broadening Elective*

5.3 Information regarding the Fundamentals of Engineering Exam

The BSIE curriculum at Clemson University is designed to offer students the opportunity to prepare for the Fundamentals of Engineering Exam. Passing the Fundamentals of Engineering (FE) Exam is the first step in pursuing a professional engineering license. The National Council of Examiners for Engineering and Surveying manages the process and documents it at their website

www.ncees.org/exams/fundamentals.

The BSIE curricula includes the following courses outside of Industrial Engineering in part to support instruction in the topics on the FE:

- Engineering Science Requirement coursework
- Ethics and Professional Practice course (in Broadening Elective for 2022 and later catalog years)
- Management Requirement course (in Broadening Elective for 2022 and later catalog years)

5.4 Prerequisites

The IE department strictly enforces course prerequisites.

Prerequisite list

The table below shows the prerequisite list for all required IE classes.

IE Course	Prerequisites
IE 2100	ENGL 1030 (C or better), PHYS 1220 (C or better)
IE 3010	ENGL 1030 (C or better)
IE 2140 / 3140	None. <i>Note:</i> Renumbered as IE 2140 effective Fall 2022
IE 3600	MATH 2060 (C or better)
IE 3610	IE 3600
IE 3800	MATH 3110 (C or better)
IE 3810	MATH 3110 (C or better), IE 3600
IE 3840	MATH 1080 (C or better)
IE 3860	IE 3800, IE 3140/2140 effective Fall 2023
IE 4400	ENGR 1410 or CPSC 1010 or 1050 or 1060 or 1110 (all with C or better)
IE 4610	IE 3610
IE 4820	IE 3610, IE 3810
IE 4880	Junior Standing and MATH 1020 or MATH 1060 or MATH 1070
IE 4670	IE 2100, IE 3010, IE 3600, IE 3610, IE 3800, IE 3810, IE 3840, IE 3860, IE 4400, IE 4610, IE 4820, IE 4880

Prerequisite flowchart Fall 2022 and Later IE and Related Course Offerings

The flowchart below shows the prerequisite requirements for IE required courses. IE courses can be taken in any semester they are offered as long as prerequisite and other requirements are satisfied.

* Must be passed with a C or better

- - - (a dotted line) Indicates Corequisites

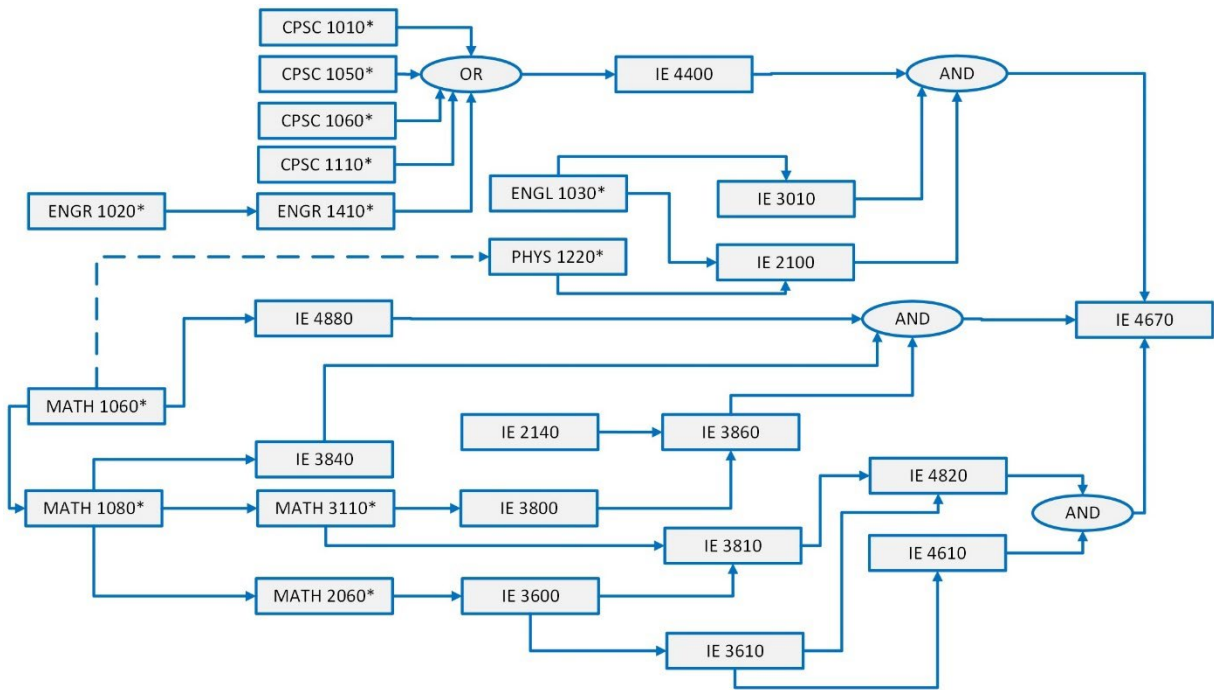

6 Planned Course Offerings

Planned course offerings for the following terms are identified in the table below. Note that this list is subject to change, but we offer all required IE classes both in the fall and spring semesters. We also plan to offer multiple IE technical electives and IE Integrating Electives in the fall and the spring semesters.

Summer 2023	Fall (in general)	Spring (in general)	Summer 2024 and later TENTATIVE!
Summer I IE 3600 (online) IE 4580 / 6580 (online) IE 4620 / 6620 (online)	IE 2100 IE 2140 IE 3010 IE 3600 IE 3610	IE 2100 IE 2140 IE 3010 IE 3600 IE 3610	Summer I IE 3600 (online)
Summer II IE 3610 (online) IE 3810 (online)	IE 3800 IE 3810 IE 3840 IE 3860	IE 3800 IE 3810 IE 3840 IE 3860	Summer II IE 3610 (online) IE 3810 (online)
Long Summer IE 3010 (in person)* IE 3840 (online) IE 4670 (in person) IE 4671 (in person) IE 4880 (online)*	IE 4400 IE 4610 IE 4670 IE 4820 IE 4880 At least 2 IE tech electives	IE 4400 IE 4610 IE 4670 IE 4820 IE 4880 At least 2 IE tech electives	Long Summer IE 3840 (online)
* Enrollment dependent	At least 2 IE Integrating Electives	At least 2 IE Integrating Electives	In some summer session At least one IE tech elect Sometimes offered, please enter into your plan so we can gauge demand IE 3010 (long, in person only) IE 4670 (long, in person only) IE 4880 (length varies, online)

7 Study Abroad

The Industrial Engineering Department encourages students to consider study abroad, whether through a summer or semester experience. If you plan to participate, you must be aware that the semester abroad may increase the course load taken in other semesters. Summer study abroad provides great opportunities!

The best advice is to plan ahead! The best semester for Study Abroad is Fall sophomore year because so many of the courses are offered at many institutions with math and engineering courses. The second best semesters are Spring sophomore year and Fall junior year because several of those IE courses are offered online in summer and you have time to rearrange your courses to accommodate the courses that are offered at your abroad institution.

8 Co-op Schedules

The Industrial Engineering Department supports the Co-operative Education Program. If you plan to participate, you must be prepared for your graduation to be delayed by one calendar year, even if you only participate in the co-op program for one regular semester.

Please consult your advisor before taking any co-op assignment, and especially before taking a co-op assignment that is not listed below. In general, the curriculum proceeds as published, simply delaying semesters based on when the co-op semesters are taken.

Standard Curriculum	
fall	spring
fa, soph	sp, soph
fa, jr	sp, jr
fa, sr	sp, sr

Co-op Option #1		
begin summer, prior to sophomore year		
fall	spring	summer
		co-op
fa, soph	co-op	
co-op	sp, soph	
fa, jr	sp, jr	
fa, sr	sp, sr	

Co-op Option #2		
begin fall, sophomore year		
fall	spring	Summer
co-op	fa, soph	co-op
sp, soph	co-op	
fa, jr	sp, jr	
fa, sr	sp, sr	

Co-op Option #3		
begin spring, sophomore year		
Fall	spring	summer
fa, soph	co-op	
co-op	sp, soph	co-op
fa, jr	sp, jr	
fa, sr	sp, sr	

Co-op Option #4		
begin summer, after sophomore year		
fall	spring	Summer
fa, soph	sp, soph	co-op
fa, jr	co-op	
co-op	sp, jr	
fa, sr	sp, sr	

Co-op Option #5		
begin fall, junior year		
fall	spring	summer
fa, soph	sp, soph	
co-op	fa, jr	co-op
sp, jr	co-op	
fa, sr	sp, sr	

9 Changing majors into IE

In order for any student to change majors into IE, the following courses must be completed with a C or better:

CH 1010	
ENGL 1030	
ENGR 1020	or ENGR 1050 and ENGR 1060
ENGR 1410	or ENGR 1070 + 1080 + 1090 or ENGR 1640 or CPSC 1010 or CPSC 1050 or CPSC 1060 or 1110
MATH 1060	or MATH 1040 and MATH 1070
MATH 1080	
PHYS 1220	

Furthermore, each student must have a 2.0 overall GPA

9.1 Changing into IE from General Engineering

1. The semester prior to entering IE, the student will meet with their GE advisor during registration advising to plan their next semester.

2. The GE student will not be able to submit their change of major until passing final grades are posted for the courses listed above.
3. The GE student will not be able to register for IE courses 3000 level or higher until their change of major is complete.

9.2 Changing into IE from other majors

1. Student must have completed the courses documented above with a C or better
2. The student must complete a course plan that documents all courses to be taken until graduation.
3. These plans can be reviewed via email by sending to the appropriate advisor identified in the Academic Advising section of this document.
4. You may also set up an "Explore Industrial Engineering" appointment with the appropriate IE academic advisor through CU Navigate.

Creating a What-If DegreeWorks Report will indicate how your courses will map to the IE curriculum. To receive credit for a course that does not appear in your DegreeWorks Report, it must be deemed equivalent to a course in the IE curriculum. In this case, you would have to submit a specific request for a course substitution (e.g., ECE xxxx for IE yyyy), along with the syllabus of the course that you believe to be equivalent.

9.3 How to change majors

After receiving approval from an academic advisor in IE:

Submit an Undergraduate Change of Program request in iROAR :

Students -> Student Records -> Undergraduate Change of Program.

For more instructions on the process in iRoar: <https://www.clemson.edu/registrar/student-menu/student-records/majors-minors.html>

10 Additional Registration and Course Planning Topics

10.1 Credit to be earned at another school

The student should obtain approval of each course *prior* to scheduling the class. By obtaining advance approval, the student is assured of receiving proper credit at Clemson upon satisfactory completion of the course. Information and forms relative to this approval may be obtained at <https://www.clemson.edu/registrar/forms/student-forms/index.html>. The *Transfer Credit Equivalency List*, which is a database containing the Clemson University course equivalencies for approximately 1200 accredited colleges and universities nationwide, may be found at <https://www.clemson.edu/admissions/tcel/>.

Please reference this list before seeking approval from your advisor. When considering taking courses elsewhere, keep in mind that to qualify for an undergraduate degree, a student must complete through instruction from Clemson *a minimum of 37 of the last 43 credits* presented for the degree. However, a waiver may be obtained for approved study abroad experiences through the Undergraduate Academic Services Office, E-103 Martin Hall.

10.2 Petitions

Students may petition for exceptions to departmental registration policies and curriculum requirements. The merits of the petition should first be discussed with your academic advisor and must be based on curricular reasons, as opposed to convenience or financial hardship. If you elect to pursue a petition, the petition form (that you must complete) and the associated documentation is routed to the Undergraduate Curriculum Committee through your academic advisor for review. The Committee makes a recommendation to the Chair, who renders a decision based on your documentation and the

recommendation of the Committee. The Undergraduate Program Coordinator will contact your academic advisor with the results of the petition.

10.3 Enrolling in a course and its prerequisites concurrently

The IE department strictly enforces prerequisite requirements. At the present time, only the following exceptions are allowed:

- IE 3860 may be taken concurrently with IE 4670 provided that MGT 3900 has been completed. Please note that MGT 3900 has the following prerequisites: MGT 2180 and IE 3610.
- IE 3610 may be taken concurrently with IE 4610 and/or IE 4820 provided that one of STAT 2300 (not AP credit), MATH 3020, or STAT 4110 has been successfully completed before either IE 4610 or IE 4820 is taken.

Summer courses offered by other institutions *may* also be a viable option to satisfy prerequisite content. It is the responsibility of the petitioner to identify any candidate course and to assemble documentation for review by the Undergraduate Committee.

10.4 IE course attempt policy (2016 – 2017 catalog year and later)

No student may exceed three attempts, including a W and grade forgiveness (with the exception of a withdrawal from the University), to complete any IE course with a grade of D or better. Moreover, a third attempt is granted by a written request to the department chair (through the Undergraduate Program Coordinator) before the deadline to add a course in a subsequent term. This policy applies only to students in the 2016 and later catalog years.

10.5 Graduate Coursework

Seniors with 3.0 or higher GPA are eligible to request enrollment in graduate level courses by completing the GS6 form. For additional information and to obtain a copy of the GS6 form please visit <https://www.clemson.edu/graduate/students/forms.html>.

Seniors with 3.4 or higher GPA are eligible to request participation in the Combined Bachelor's/Master's Plan. Under this plan, students may reduce the time necessary to earn a master's degree by applying graduate credits to both undergraduate and graduate program requirements. Interested students need to complete the GS6-Bachelor-to-Graduate form. For additional information and to obtain a copy of the GS6-Bachelor-to-Graduate form please visit <https://www.clemson.edu/graduate/students/forms.html>.

What is the difference between GS6 and GS6-Bachelor-to-Graduate forms? In the IE Department, the GS6-Bachelor-to-Graduate form allows IE students to double-count up to 12 credit hours towards both BS and MS requirements. The credit hours counted towards the bachelor's degree plus the credit hours taken after the bachelor's is awarded must total at least 150. For the bachelor's and PhD, the total must be 180 credit hours. The GS6 form allows you to take graduate level courses, but there is no double-counting. Graduate courses taken using the GS6 form can either be used to meet BS requirements or MS requirements but not both.

11 Expanding Experiences Outside of the Classroom

11.1 Creative Inquiry (CI)

CI provides opportunities in the form of open-ended problems that extend beyond the classroom. These research experiences are guided by one or more faculty mentors and will typically involve other undergraduate and graduate students. Industrial Engineering CIs are limited both by the number of faculty participating and the number of slots available in the groups of the participating faculty. In order to be considered as a member of a research group, you must first apply. The application process varies across the faculty, from very informal to formal. It may include an interview and/or a written statement of purpose (a brief essay about one's research goals, including motivation), for example;

GPA may also be a criterion. General information about CI may be found at <http://www.clemson.edu/centers-institutes/watt/creative-inquiry/>.

Universal CIs are listed on the Creative Inquiry website with details on how to apply. Universal CIs do not count towards the IE curriculum but are encouraged experiences. Departmental CIs (IE 4040) are listed in Banner and the student may contact the faculty member for details on how to apply. Departmental CI experiences (IE4040) may count towards the IE Technical Requirements with a maximum of 6-credits.

11.2 IE 2680: CI Seminar

IE 2680/2680 (HON) is our introductory CI course. It is a one-hour seminar that is graded on a pass/fail basis. The objectives of this seminar are to introduce the research process and to make known research opportunities in the Department. It is one way to dip your toe into the water before diving in, so to speak. Faculty mentors may require IE 2680 of other students at their discretion. IE 2680/2680 (HON) does not necessarily have to be taken prior to beginning the IE 4040/4000 (HON) sequence. In instances where it is required, individual mentors may permit it to be taken concurrently.

11.3 Departmental Honors

Departmental Honors, unlike General Honors, is thesis-based rather than course-based. The IE honors students must complete IE 2680 (HON) and IE 4000 (HON). These courses serve as a mechanism to get academic credit for the thesis. While the word ‘thesis’ may be somewhat intimidating, it basically documents the research process and outcomes. If students are researching in a team setting, each student must make a distinct contribution, but team members may submit a common document as his or her thesis. Honors students may satisfy up to 6 hours of the IE technical requirement by completing their 6-hour thesis requirement, IE 4000 (HON). For additional information please visit <https://www.clemson.edu/cuhonors/current-students/student-handbook/departmental-honors.html>.

11.4 Course and curriculum requirements of other departments

There are certain curriculum requirements of other departments that do not currently apply to IE majors. One example is the requirement of the mechanical engineering curriculum that “a student is allowed to enroll in any ME course only when all prerequisites, as defined by current official listings for that course, have been passed with a grade of C or higher”. However, requirements of courses apply to all students in all majors taking that course. For example, as of Fall 2012, CE 2080 requires CE 2010 be passed with a C or better. Since this is a course requirement, it applies to all students.

Contact the Undergraduate Coordinator if you should experience any difficulty with these course registrations.

12 Information for Non-IE and Transfer Students

General Engineering students are permitted to enroll in industrial engineering courses, but only those at the 2000-level. Other qualified students are also permitted to enroll in IE courses, although a cumulative GPA of 2.0 or higher is required for registration in courses numbered 3000 or higher. Priority for registration in these courses is given to those majors for whom the course is a degree requirement.

13 IE Objectives and Outcomes

Program Educational Objectives:

Within 3-5 years of graduation, BSIE students will:

- Build a record of successful work experiences designing, developing, implementing and/or improving engineering systems.

- Demonstrate a commitment to professional development through the pursuit of professional certification, advanced degrees, and/or knowledge of advances in their field.
- Take on greater responsibility or leadership roles in their workplace, profession, and/or community.

Program Educational Objectives Affirmed by the IE department October 9, 2019.

Student Outcomes

By the time of graduation, BSIE students will have:

- an ability to identify, formulate, and solve complex engineering problems by applying principles of engineering, science, and mathematics
- an ability to apply engineering design to produce solutions that meet specified needs with consideration of public health, safety, and welfare, as well as global, cultural, social environmental, and economic factors
- an ability to communicate effectively with a range of audiences
- an ability to recognize ethical and professional responsibilities in engineering situations and make informed judgements, which must consider the impact of engineering solutions in global, economic, environmental, and societal contexts
- an ability to function effectively on a team whose members together provide leadership, create a collaborative and inclusive environment, establish goals, plan tasks, and meet objectives
- an ability to develop and conduct appropriate experimentation, analyze and interpret data, and use engineering judgement to draw conclusions
- an ability to acquire and apply new knowledge as needed, using appropriate learning strategies.

Student Outcomes adopted by the IE department May 8, 2019